

Product safety

Please read these instructions before operating the appliance and retain them for future use.

- ⚠ This product is not suitable for use by children, and may not be suitable for persons requiring supervision unless they receive instruction by a competent person on how to safely use the product.
- ⚠ Children should be supervised to ensure that they do not play with the product.
- ⚠ This appliance generates heat during use. Adequate precaution must be taken to prevent the risk of burns, scalds, fires or other damage to persons or property caused by touching the exterior whilst in use or during cooling.
- ⚠ Never use this appliance for anything other than its intended use. This appliance is for household use only. Do not use this appliance outdoors.
- ⚠ Always ensure that hands are dry before handling the plug or switching on the appliance.
- ⚠ Always use the appliance on a stable, secure, dry and level surface.
- ⚠ Never use a power base other than the one supplied with the appliance.
- ⚠ This appliance must not be placed on or near any potentially hot surfaces (such as a gas or electric hob).
- ⚠ The power cord is not replaceable by the user. Always return the appliance if the power cord is damaged to avoid any hazard.
- ⚠ Do not use the appliance if it has been dropped, if there are any visible signs of damage or if it is leaking.
- ⚠ Ensure the appliance is switched off and unplugged from the supply socket after use and before cleaning.
- ⚠ Always allow the appliance to cool before cleaning or storing.
- ⚠ Never immerse any part of the appliance or power cord and plug in water or any other liquid.
- ⚠ Never let the power cord hang over the edge of a worktop, touch hot surfaces or become knotted, trapped or pinched.
- ⚠ Never leave the appliance unattended when in use.
- ⚠ Beware of steam coming from the spout or lid especially during refilling. Never open the lid during the boiling cycle.
- ⚠ Never fill the appliance when it is positioned on the power base.
- ⚠ Never fill the kettle above the MAX marking. If the kettle is overfilled, boiling water may be ejected.
- ⚠ Never use the kettle without sufficient water in the kettle for it to operate correctly.
- ⚠ Never allow the appliance to boil dry.

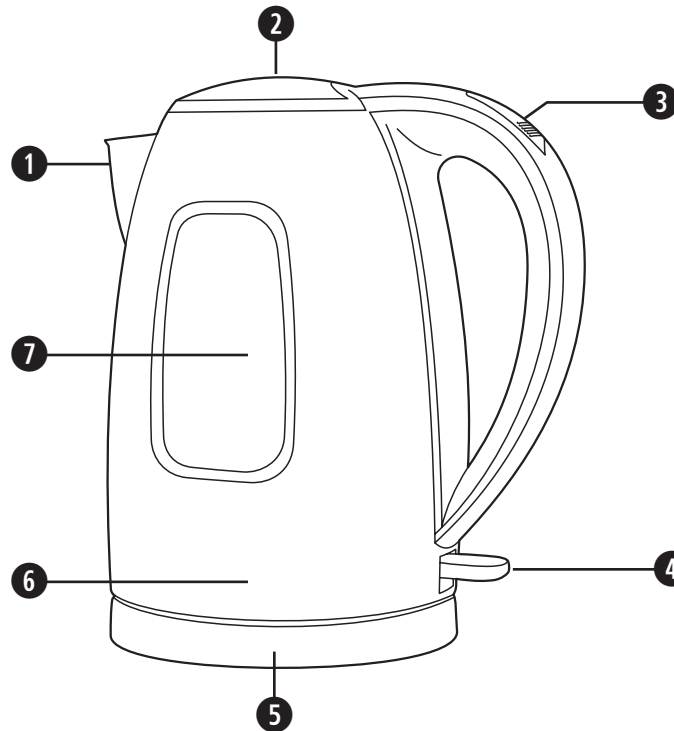

- 1 Spout
- 2 Lid
- 3 Lid release button
- 4 On/off switch
- 5 360° rotational power base with cord storage
- 6 Easy clean, fast boil concealed element
- 7 Water level window

Before using for the first time

Remove any packaging and promotional material from your kettle and position it on a stable, secure, dry and level work surface away from the edge.

Before connecting to a power source, make sure your mains supply voltage is the same as the one indicated on the appliance. Connect the plug to a suitable power outlet and make sure that the power cord does not overhang the work surface. Excess power cord can be stored in the power base.

- Fill your kettle to the maximum mark and close the lid.
- Place the kettle back onto the power base. Switch the kettle on, allow it to boil then discard the water. Repeat twice. This will remove any residue left over from the manufacturing process.

Using your kettle

⚠ If this kettle is filled above the maximum level mark, hot water may be ejected from the spout during boiling. Beware of steam coming from the spout or lid especially during refilling. Never open the lid when the kettle is boiling.

1. With the kettle switched off, plug the power base into a suitable power outlet.
2. Remove the kettle from the power base before filling it with water. Do not fill the kettle through the spout.
3. Fill the kettle with water. Don't overfill the kettle and always ensure that there is sufficient water in the kettle for it to operate correctly. This is approximately 250ml or 1 teacup full. Always check the water level when the kettle is positioned on its power base.
4. Make sure that the lid is closed correctly to ensure safe operation.
5. When the kettle is switched on, the water level window will illuminate.
6. When the water reaches boiling point, the kettle will switch off automatically.
7. You may also switch the kettle off manually at any time by moving the switch to the off position.

Always use caution when carrying or pouring water from your kettle when it is full of hot or boiling water.

If your kettle boils dry

If the kettle is operated with insufficient water a built in fail-safe device will automatically switch off the kettle.

- Unplug the kettle and allow it to cool. When the kettle has cooled down sufficiently the device will reset itself.
- Once the device has reset, refill the kettle with cold water and use it as normal.

Energy saving hints and tips

A Breville kettle, if used correctly, is a very energy efficient device. Why not try some of these energy saving tips:

- Only boil the water you need. Overfilling your kettle by one cup is the equivalent to using an energy saving light bulb for one hour!
- It is not always necessary to re-boil your kettle. For example, one litre of water will still be at 90°C after five minutes - the perfect temperature for a cup of coffee.

Care and cleaning

▲ Always unplug the kettle from the mains supply socket and allow it to completely cool down before cleaning or descaling it. Do not immerse the kettle, power base or power cord and plug in water or any other liquid.

1. Clean the exterior surface of the kettle with a damp cloth and then polish with a soft dry cloth. Do not use steel wool pads or harsh/abrasive cleaners.
2. Descale your kettle regularly to keep it working efficiently. Use a proprietary descaling product following the manufacturer's instructions carefully.

Cleaning the filter

- Open the lid and remove the filter from behind the spout.
- Rinse the filter under a tap whilst brushing it with a soft brush. In hard water areas it may be necessary to descale the filter using a descaling agent.
- Use a proprietary descaling product following the manufacturer's instructions carefully. The filter may be washed safely in the cutlery rack of a dishwasher.
- Refit the filter back into the kettle.

Replacement filter

A replacement filter can be obtained by phoning our Customer Service Department on 0161 621 6900. They will give you up to date prices, inclusive of VAT and postage and packaging.

Filter part number	91345
--------------------	-------

Guarantee

This product is guaranteed for a period of 1 year from the date of purchase against mechanical and electrical defects.

This guarantee is only valid if the appliance is used solely for domestic purposes in accordance with the instructions provided, that it is not connected to an unsuitable electricity supply, dismantled or interfered with in any way or damaged through misuse. Under this guarantee we undertake to repair or replace free of charge any parts found to be defective.

Nothing in this guarantee or the instructions relating to the product excludes, restricts or otherwise affects your statutory rights.

In line with our policy of continuous development, we reserve the right to change this product, packaging and documentation without notice.

Electrical safety

▲ This appliance must be earthed.

This appliance is fitted with either a moulded or rewirable BS1363, 13 amp plug. The fuse should be rated at 13 amps and be ASTA approved to BS1362. If the fuse in a moulded plug needs to be changed, the fuse cover must be refitted. The appliance must not be used without the fuse cover fitted.

If the plug is unsuitable, it should be dismantled and removed from the supply cord and an appropriate plug fitted as detailed below. If you remove the plug it must not be connected to a 13 amp socket and the plug must be disposed of immediately.

If any other plug is used, a 13 amp fuse must be fitted either in the plug or adaptor or at the distributor board.

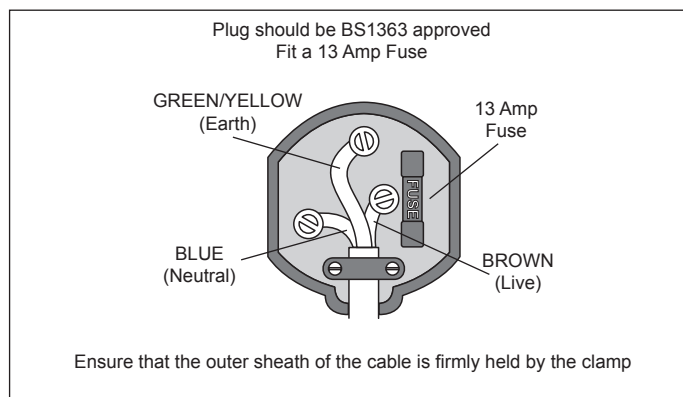

After sales service

To return a faulty appliance to our Customer Service Department:

1. Pack it carefully (preferably in the original carton). Ensure the unit is clean.
2. Enclose your name and address and quote the model number on all correspondence. Give the reason why you are returning it.
3. If within the guarantee period, state when and where it was purchased and include proof of purchase (e.g. till receipt).
4. Send it to our Customer Service Department at the address below:

**Customer Service Department
Pulse Home Products Limited
Middleton Road
Royton
Oldham
OL2 5LN, UK.
Telephone: 0161 621 6900 Fax: 0161 626 0391
e-mail: info@pulse-uk.co.uk**

Breville

stainless steel
jug kettle
instruction booklet

www.breville.co.uk