

Breville®



stainless steel 4 slice toaster

Here to help...



0161 621 6900

www.breville.co.uk



enquiriesEurope@jardencs.com



www.breville.co.uk/faqs

Find Breville UK at...



YouTube

For hints, tips and over 200 recipes, visit...

creative
kitchen

brevillecreativekitchen.co.uk

Product safety

Please read these instructions before operating the appliance and retain them for future use.

This product can be used by children aged 8 years and above, and persons who require supervision, provided:

- they are familiar with the hazards associated with the product, and,
- they receive instruction by a competent person on how to safely use the product.

Children must not play with the product. Cleaning and user maintenance must not be done by children unless they are supervised.

Keep the appliance and its cord out of reach of children less than 8 years old.

Bread can burn therefore do not use the appliance near or below combustible materials such as curtains. Never use the appliance below wall cupboards or shelves.

Never operate the appliance by means of an external timer or separate remote-control system.

Do not touch the metal parts of the appliance during use as they may become very hot.

If the supply cord is damaged, it must be replaced by the manufacturer, its service agent or similarly qualified persons in order to avoid a hazard.

- ⚠ Never use this appliance for anything other than its intended use. This appliance is for household use only. Do not use this appliance outdoors.
- ⚠ Always ensure that hands are dry before handling the plug or switching on the appliance.
- ⚠ Always use the appliance on a stable, secure, dry and level surface.
- ⚠ This appliance must not be placed on or near any potentially hot surfaces (such as a gas or electric hob).
- ⚠ Do not use the appliance if it has been dropped or if there are any visible signs of damage.
- ⚠ Ensure the appliance is switched off and unplugged from the supply socket after use and before cleaning.
- ⚠ Always allow the appliance to cool before cleaning or storing.
- ⚠ Never immerse any part of the appliance or power cord and plug in water or any other liquid.
- ⚠ Never let the power cord hang over the edge of a work top, touch hot surfaces or become knotted, trapped or pinched.
- ⚠ Never leave the appliance unattended when in use.
- ⚠ Before connecting to a power source, make sure your mains supply voltage is the same as the one indicated on the appliance.

- ⚠ Never force bread into the toasting slots.
- ⚠ Never toast slices of bread that have been buttered.
- ⚠ Never use your toaster with any food item that contains sugar, or any product that contains jam or preserves.
- ⚠ Don't use bent, damaged or broken bread in your toaster.

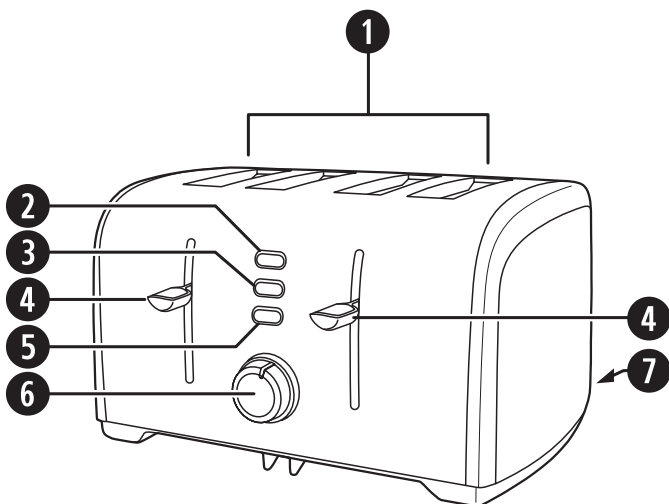

- 1 Bread slots
- 2 Cancel button
- 3 Reheat button
- 4 Loading handle with high lift feature
- 5 Frozen bread button
- 6 Browning control
- 7 Crumb tray (x2 at the rear of the toaster)

Before using for the first time

Carefully remove your toaster from its box. Remove all packaging from inside the toasting slots.

Position your toaster on a stable, secure, dry and level work surface away from the edge. Connect the plug to a suitable power outlet and make sure that the power cord does not overhang the work surface.

When you first use your toaster, there may be a slight odour as the heating elements warm up for the first time. This is normal and not a cause for concern. To remove the odour, simply operate your toaster for the first time without any bread in it.

Controls

BROWNING CONTROL

The browning control **6** regulates how much the bread is toasted—in other words, the colour of the toast. Lower settings produce lighter toast and higher settings produce darker toast.

When setting the browning control, remember that dry or thin slices of bread will toast quicker and require a lower setting. Moist or thick slices of bread will require a higher setting.

CANCEL BUTTON

The toasting process can be stopped at any time by pressing the cancel button **2**.

HIGH LIFT FEATURE

The high lift feature uses the loading handle **4** to help you to remove the toast. When toasting has finished, simply lift the loading handle upwards from its rest position to raise the toast and make it easier to remove.

FROZEN BREAD FUNCTION

The frozen bread function allows you to toast bread straight from the freezer. Insert the bread into your toaster, press the loading handle down and then press the frozen bread button **5**. Your toaster will extend the toasting time to allow the bread time to defrost. Watch the toast to ensure that it doesn't burn.

REHEAT FUNCTION

The reheat function will heat up toast that has cooled or gone cold. Press the loading handle down then press the reheat button **3**. Watch the toast to ensure that it doesn't burn. Don't use the reheat function on buttered toast.

Using Your Toaster

1. Set the level of toasting using the browning control **6**. The higher the number selected, the darker the toast will be.
2. Place the bread into the toasting slots. Press the loading handle **4** down until it latches. The bread will be lowered into the toaster and toasting will begin. **The loading handle will not latch if your toaster is not connected to the mains supply.**
3. When toasting has finished, the loading handle will rise and the toasted bread can be removed. You can lift the loading handle upwards beyond its rest position to help you remove the toast.
4. If the toast is not done enough it can be toasted again. Turn the browning control to a lower setting and watch the toast to ensure that it doesn't burn.
5. Toasting can be stopped at any time by pressing the cancel button **2**.

If you are toasting a single slice of bread, set the browning control to a lower setting than normal. By using a lower setting when toasting a single slice of bread, it will not be over toasted.

If Your Toaster Jams

Never use a knife or any other utensil or implement to remove jammed bread. Never insert your fingers into the bread slots.

1. Unplug the toaster from the mains supply socket.
2. Allow the toaster to completely cool down.
3. Carefully ease the bread out of the toaster being careful not to damage the heating element.

Cleaning

Clean the outside of your toaster with a damp cloth then dry thoroughly. Never use harsh, abrasive or caustic cleaners.

Crumb Removal

It is important that crumbs are not allowed to build up inside your toaster. Excess crumbs are unhygienic and could catch fire.

Crumbs can be removed by sliding the crumb trays out from the bottom of your toaster. You can then tip the crumbs out. Always make sure that your toaster has completely cooled down and is disconnected from the mains supply before removing crumbs. Never use your toaster without the crumb trays fitted—always replace the crumb trays before using your toaster.

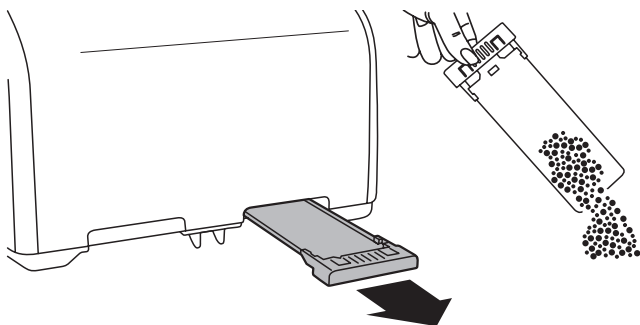

Replacement parts

For additional or replacement parts, please visit www.breville.co.uk or call us on 0161 621 6900.

Troubleshooting

For troubleshooting and FAQs visit www.breville.co.uk/faqs

Creative Kitchen

Visit Creative Kitchen for access to the best cooking techniques, mouth-watering meals, entertaining ideas and videos to help take you from part-time cook to expert chef in minutes. Enjoy getting creative with your home cooking at:

www.brevillecreativekitchen.co.uk.

creative
kitchen

After sales service

To return a faulty appliance to our Customer Service Department:

1. Pack it carefully (preferably in the original carton). Ensure the unit is clean.
2. Enclose your name and address and quote the model number (located on the rating label) on all correspondence. Give the reason why you are returning it.
3. If within the guarantee period, state when and where it was purchased and include proof of purchase (e.g. till receipt).
4. Send it to our Customer Service Department at the address below:

Customer Service Department
Jarden Consumer Solutions (Europe) Limited
5400 Lakeside, Cheadle Royal Business Park,
Cheadle, SK8 3GQ
Telephone: 0800 525 089 Fax: 0161 626 0391
e-mail: enquiriesEurope@jardencs.com

Electrical safety

⚠ This appliance must be earthed.

This appliance is fitted with either a moulded or rewirable BS1363, 13 amp plug. The fuse must be ASTA approved to BS1362. If the fuse in a moulded plug needs to be changed, the fuse cover must be refitted. The appliance must not be used without the fuse cover fitted.

If the plug is unsuitable, it should be dismantled and removed from the supply cord and an appropriate plug fitted as detailed below. If you remove the plug it must not be connected to a 13 amp socket and the plug must be disposed of immediately.

If any other plug is used, a 13 amp fuse must be fitted either in the plug or adaptor or at the distributor board.

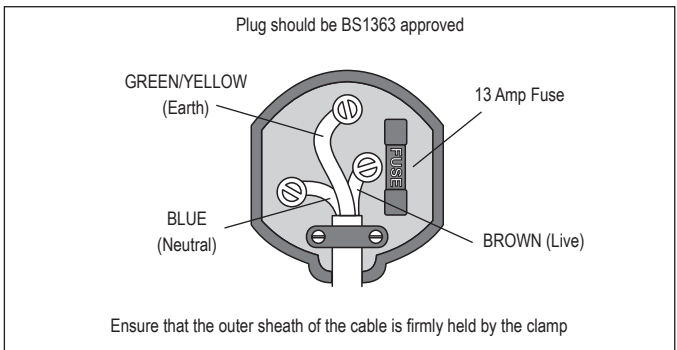

Guarantee

Please keep your receipt as this will be required for any claims under this guarantee.

This appliance is guaranteed for 1 year after your purchase as described in this document.

During this guaranteed period, if in the unlikely event the appliance no longer functions due to a design or manufacturing fault, please take it back to the place of purchase, with your till receipt and a copy of this guarantee.

The rights and benefits under this guarantee are additional to your statutory rights, which are not affected by this guarantee. Only Jarden Consumer Solutions (Europe) Limited ("JCS (Europe)") has the right to change these terms.

JCS (Europe) undertakes within the guarantee period to repair or replace the appliance, or any part of appliance found to be not working properly free of charge provided that:

- you promptly notify the place of purchase or JCS (Europe) of the problem; and
- the appliance has not been altered in any way or subjected to damage, misuse, abuse, repair or alteration by a person other than a person authorised by JCS (Europe).

Faults that occur through improper use, damage, abuse, use with incorrect voltage, acts of nature, events beyond the control of JCS (Europe), repair or alteration by a person other than a person authorised by JCS (Europe) or failure to follow instructions for use are not covered by this guarantee. Additionally, normal wear and tear, including, but not limited to, minor discolouration and scratches are not covered by this guarantee.

The rights under this guarantee shall only apply to the original purchaser and shall not extend to commercial or communal use.

If your appliance includes a country-specific guarantee or warranty insert please refer to the terms and conditions of such guarantee or warranty in place of this guarantee or contact your local authorized dealer for more information.

Waste electrical products should not be disposed of with Household waste. Please recycle where facilities exist. E-mail us at enquiries info@pulse-uk.co.uk for further recycling and WEEE information.

Jarden Consumer Solutions (Europe) Limited
5400 Lakeside
Cheadle Royal Business Park
Cheadle
SK8 3GQ
UK

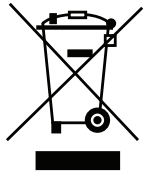

Breville

Jarden Consumer Solutions (Europe) Limited
Cheadle Royal Business Park, Cheadle, SK8 3GQ, United Kingdom
e-mail: enquiriesEurope@jardencs.com
Telephone: 0161 621 6900

For Customer Service details, please see the website.

www.breville.co.uk

© 2014 Jarden Consumer Solutions (Europe) Limited.

All rights reserved. Imported and distributed by Jarden Consumer Solutions (Europe) Limited,
Cheadle Royal Business Park, Cheadle, SK8 3GQ, United Kingdom.
Jarden Consumer Solutions (Europe) Limited is a subsidiary of Jarden Corporation (NYSE: JAH).

The product supplied may differ slightly from the one
illustrated due to continuing product development.

Printed In China