

Breville®

Turn **on** your creativity™



pick and mix
glass blender

READ CAREFULLY AND KEEP FOR FUTURE REFERENCE

This appliance can be used by children aged from 8 years and above and persons with reduced physical, sensory or mental capabilities or lack of experience and knowledge if they have been given supervision or instruction concerning use of the appliance in a safe way and understand the hazards involved. Children shall not play with the appliance. Cleaning and user maintenance shall not be made by children without supervision.

Always disconnect the appliance from the mains supply socket if it is left unattended and before assembling, disassembling or cleaning.

If the supply cord is damaged, it must be replaced by the manufacturer, its service agent or similarly qualified persons in order to avoid a hazard.

- ⚠ Never use this appliance for anything other than its intended use. This appliance is for household use only. Do not use this appliance outdoors.
- ⚠ Always ensure that hands are dry before handling the plug or switching on the appliance.
- ⚠ Always use the appliance on a stable, secure, dry and level surface.
- ⚠ This appliance must not be placed on or near any potentially hot surfaces (such as a gas or electric hob).
- ⚠ Never immerse any part of the appliance or power cord and plug in water or any other liquid.
- ⚠ Never let the power cord hang over the edge of a work top, touch hot surfaces or become knotted, trapped or pinched.
- ⚠ Do not use the appliance if it has been dropped or if there are any visible signs of damage.
- ⚠ Never use any accessory or attachment not recommended by the manufacturer.
- ⚠ Make sure that all attachments are securely and correctly fitted before operating the appliance.
- ⚠ The blades and cutting accessories have very sharp edges. Take care when handling or cleaning them.
- ⚠ Allow moving parts to come to a stop before changing or cleaning accessories.
- ⚠ Never process hot or boiling liquids. Allow them to cool before processing.

before using your blender

▲ Ensure that the appliance is switched off and unplugged from the supply socket if it is left unattended and before assembling, disassembling or cleaning.

The blades have very sharp edges. Take care when handling or cleaning them.

Never immerse any part of the appliance or power cord and plug in water or any other liquid.

Never use harsh, abrasive or caustic cleaners to clean this appliance.

1. Remove your blender carefully from the packaging. You may wish to store the packaging for future use.
2. Check the contents:
 - Motor unit
 - Jug
 - Lid
 - Stopper
3. Wash all parts that will come into contact with food. Use warm soapy water then rinse and dry thoroughly.
4. Using a mild detergent solution, wipe the motor unit with a damp cloth. Dry thoroughly.

features

1 Stopper

Removable stopper allows you to add ingredients whilst continuing to blend

2 Jug lid

3 Glass jug

4 Base unit

5 Speed control

Illuminated speed control with two speeds plus ice crush

6 Pulse button

The Pulse button allows precise control of the duration and speed of blending. Press and hold the pulse button to start processing, and release it to stop.

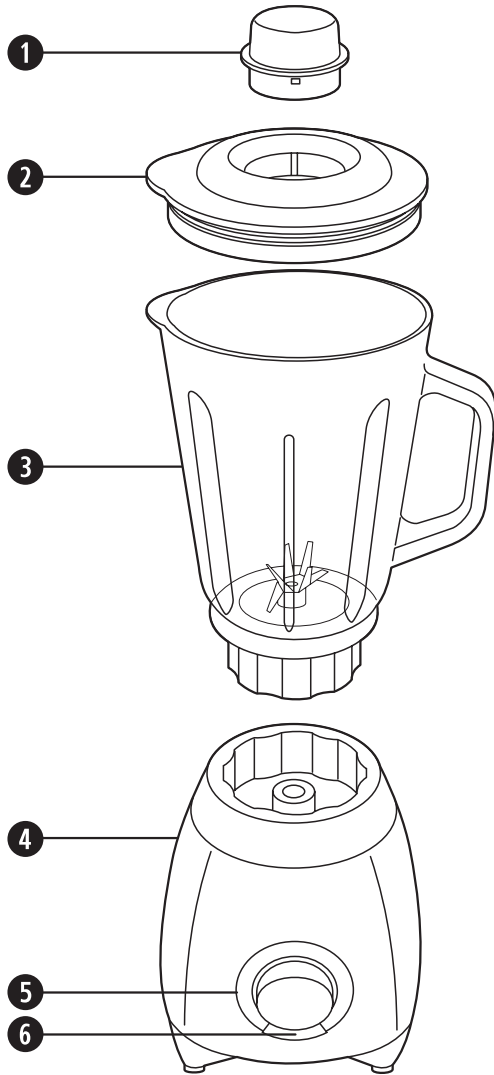

Due to our policy of continuous improvement, the actual product may differ slightly from the one illustrated in these instructions.

using your blender

▲ Make sure the unit is switched off and unplugged from the mains supply socket before assembly.

Make sure that the speed control is set to the off (0) position before plugging your blender in to the mains supply.

Never place your fingers inside the jug during operation or when adding ingredients.

1. Place the jug onto the base by lining up the recesses on the jug with the lugs on the base. Make sure that the jug is seated squarely and securely on the base.
2. Add the ingredients to the blending jug. Don't overfill the jug.
3. Fit the lid onto the jug. Make sure that the spout cover on the lid aligns with the spout on the jug. Push down until the lid is securely fitted.
4. Fit the stopper. Line up the lugs on the stopper with the slots in the lid. Push the stopper down and twist it clockwise to lock it into position.
5. During processing, further ingredients can be added by twisting and removing the stopper in the lid. Refit the stopper after adding any ingredients.

Blending

▲ Do not operate your blender continuously for more than one minute without giving it a rest period of two minutes.

Place one hand on top of the lid to steady your blender during processing.

To start blending, set the speed control to **1**. To blend at a higher speed, set the speed control to **2**.

Alternatively, blend food using the pulse button. Set the speed control to the off (**0**) position then blend in short bursts by pressing and releasing the pulse button.

During blending the stopper can be removed to feed ingredients into the jug.

Using your blender to crush ice

For best results defrost ice cubes slightly before crushing. To crush home made (small) ice cubes fill the jug to 750ml and add 200ml water. To crush shop-bought (large) ice cubes add 15 ice cubes to the blender jug and add 200ml of water.

1. Place the ice cubes and water inside the jug.
2. Fit the lid and stopper. Set the speed control to the off (**0**) position before plugging the blender in to the mains supply.
3. Blend in short bursts by holding then releasing the speed control in the ICE CRUSH position.

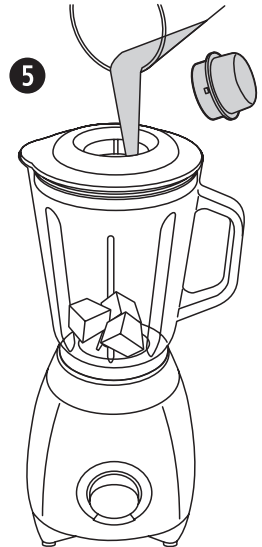
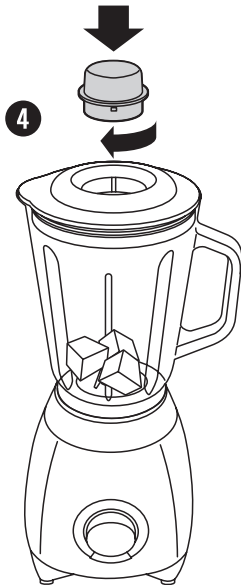
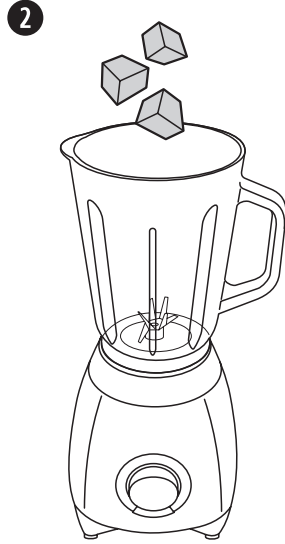
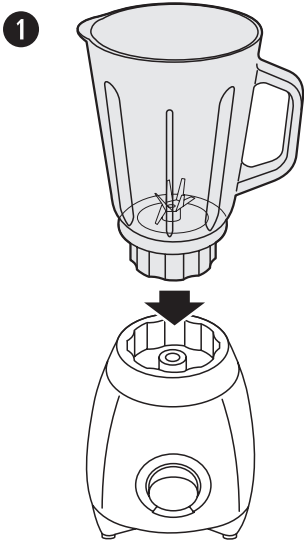

Knickerbocker Glory Serves 4

Many different flavours of ice-cream, fruit, meringue and jelly can be used to make a Knickerbocker glory. To serve, always try to use a tall sundae-style glass with a long handled spoon—perfect for reaching those delicious flavours at the bottom.

- Two jellies of your choice (strawberry and orange work well).
- 1 small tin of fruit cocktail or peaches in fruit juice
- 1 punnet of fresh berries (strawberries, raspberries or blueberries)
- Ice-cream of your choice
- 200ml of double cream

Sundae toppings (these can be any of the following or a combination of your favourite)

- Grated chocolate, fruit sauce, chopped nuts, fudge/chocolate chips, fresh berries, sugar sprinkles etc)
1. Make up the jelly in advance. This can be done the day before. To make two Knickerbocker glories, only half of each jelly is required, so ideally just use half a packet of each. For an extra fruity flavour add a splash of your favourite fruit juice to the water when preparing the jellies. Alternatively use the juice from the tinned fruit. Place the jellies in 2 separate bowls and chill to set.
 2. Using the blender whip up the double cream transfer into a suitable container and set aside in a refrigerator.
 3. Once the jellies have set, cut into chunks and place into the blending jug, using one of the flavours at a time to keep them separate. Process till chopped into small dice. Repeat with the other flavour.
 4. Assemble your Knickerbocker Glory to serve immediately,
 5. Place a small amount of the fruit into the bottom of the glass, top with a layer of jelly, add a couple of scoops of your chosen ice-cream.
 6. Repeat again until the dessert is almost at the top of the glass.
 7. Pipe or spoon the whipped cream on top and decorate with your preferred toppings.
 8. Place the spoon into the side of the glass and serve.

For a quick and easy berry coulis to use in your dessert why not blend 200g strawberries or a combination of raspberries and strawberries together in your blender with 2 tbsp icing sugar. Blitz until smooth. Strain through a sieve to remove the pips, adjust the sweetness if required and chill until ready to use.

Basic Pancake Batter Makes 8 pancakes

- 1 medium egg and one yolk
- ½ pint/280ml milk
- 4oz/110g plain flour (4 heaped dessertspoons)
- Pinch of salt
- 1 tbsp melted butter

Add all the ingredients to the blender jug and blend on speed 1 for 10 seconds. Increase the speed setting to 2 for a further 10 seconds until smooth. The batter mix should resemble thin cream.

To make pancakes

1. Heat a suitable frying pan (ideally 24cm non stick frying pan) until hot.
2. Add a drizzle of vegetable oil and a small knob of butter. Pour in a thin stream of the batter mix moving the pan around until the mixture coats the bottom of the pan.
3. Remember only a small amount is required as pancakes are at their best when thin and crispy around the edges.
4. Cook over a medium heat for a couple of minutes until the bottom looks golden brown when lifted at the edges.
5. Lifting the pan from the heat, shake gently to move the pancake and flip over. Cook for a further 2 minutes until golden brown.
6. Turn onto a warmed plate and serve with your favourite choice of topping.

Vanilla cupcakes Makes 12 deep cup cakes

- 200g butter
 - 200g caster sugar
 - 1½ tsp vanilla extract
 - 200g self raising flour
 - 1 ½ tsp baking powder
 - 3 medium eggs
 - 1 tbsp milk
1. Heat the oven to 170°C 325°F gas mark 3
 2. Place the butter in a bowl and microwave until melted. Set aside.
 3. Mix the flour and baking powder together.
 4. Add the sugar and vanilla extract to the blender jug and blend on speed 1 for 15 seconds.
 5. Remove the stopper from the blender lid and slowly pour in half of the melted butter, pulse blend until the butter is incorporated into the mixture. Repeat the process using the remainder of the butter.
 6. Add the eggs 1 at a time and blend for 10 seconds between each addition.
 7. Replace the stopper and remove the lid.
 8. Spoon in half of the flour and replace the lid. Blend for 10 seconds.
 9. Add the remainder of the flour along with the milk and blend for a further few seconds until the flour is combined into the cake mixture. You may find that a small amount of the flour sticks to the side of the jug when blending. As with most cake mixes we advise that you switch off the machine and scrape down the sides of the jug using a plastic spatula.
 10. Place 12 paper cup cake cases into a suitable bun tin and spoon in the mixture. The cases should be just over half full.
 11. Place in a hot oven and bake for 20 minutes until golden brown and risen.
 12. Allow to cool before topping with Vanilla Frosting and your favourite cake decorations.

Vanilla Frosting Makes enough to decorate 12 cup cakes

- 75g softened butter
 - 400g sifted icing sugar
 - 3 tbsp milk
 - 1½ tsp vanilla extract
1. Add the softened butter to the blender jug, add the milk and half of the icing sugar.
 2. Pulse blend for 15 seconds until the icing sugar is incorporated into the butter.
 3. Add the vanilla extract and the rest of the icing sugar and blend until combined. You will find that you may need to scrape down the sides of the jug to mix in any icing sugar which has not been immediately captured.
 4. Spoon or pipe onto your cooled cup cakes and decorate as required.

Tip Why not try adding a splash of your favourite food colouring to small batches of the frosting and make some pretty pick and mix shades!

Berry Smoothie Serves 4

The ingredients in this berry smoothie can be altered to incorporate your favourite fruits. Look out for frozen smoothie mixes in the freezer cabinet at your local supermarket

- 450 g bag frozen summer berry fruit mix
 - 450g fat free strawberry yoghurt
 - 100ml chilled semi skimmed milk
 - 2 tbsp runny honey.
1. Add all the ingredients to the blender jug and select speed 1. Blend for 10 seconds. Increase the speed to level 2 and blend for a further 10 seconds until smooth and frothy.
 2. Serve in tall glasses and drink immediately.

Peachy Mango Smoothie Serves 2

- 3 ripe peaches
 - 2 ripe mangos
 - ½ lemon, juiced
 - 150ml of white grape juice
 - A hand full of ice cubes
1. Cut the mango in half and carefully remove the stone. Remove the mango flesh and chop into chunks.
 2. Do the same to the peaches.
 3. Add the mango, peach, white grape juice and lemon juice to the blender and then mix on a low speed setting until smooth.
 4. Pour the smoothie over ice and enjoy.

Watermelon and Strawberry Refresher Serves 2

- 500g seeded chilled watermelon
 - 100g strawberries, washed and hulled
 - Juice and zest of 1 large lemon
 - 30g caster sugar
 - 100ml water
 - 6 ice cubes
 - 100ml sparkling water.
1. Add all the ingredients apart from the sparkling water to the blender jug. Blend on speed 1 until blended together.
 2. Pour into two tall slender glasses and top with the chilled sparkling water. Stir to combine and enjoy

Oreo Cookie Milkshake Serves 2

- 10 Oreo Cookies
 - 5 scoops of good quality vanilla ice cream
 - 200ml milk
 - A good squeeze of chocolate syrup
1. Break up the Oreo cookies into the blender and pulse until crumbled.
 2. Open the lid and add the ice cream, milk and chocolate syrup.
 3. Blend all the ingredients together on a speed setting 2 until combined.
 4. Serve immediately.

Blended Mojitos Cocktail Serves 2

- 8 large fresh mint leaves,
 - 2 tbsp granulated sugar or vanilla sugar (vanilla sugar can be made by submerging vanilla pods in castor or granulated sugar for a period of time)
 - 3 limes, juice extracted.
 - 2 measures of white rum
 - Ice cubes
 - Chilled soda water
 - Lime wedges and mint sprigs for garnishing
1. Place the mint leaves, sugar, rum and lime juice into a bowl.
 2. Using the bottom of a rolling pin, crush the ingredients together to infuse the flavours and set aside for at least 2 hours at room temperature. This really does make a difference to the flavours when they are allowed to develop together.
 3. Add approx 10 cubes of ice to the blender jug and using a sieve strain the infused rum and mint mixture on top. Add 300ml of soda water and blend together until thoroughly mixed.
 4. Select two tall slender glasses, divide the drink between them topping up with extra soda if required. Garnish with lime wedges and mint sprigs.

Why not try adding a measure of passion fruit liquor, along with a measure of rum and some fresh passion fruit seeds for a Mojito with a twist!

Roasted Red Pepper and Tomato Soup Serves 4

- 3 red pepper, de-seeded and halved
 - 1 onion, unpeeled and halved
 - 4 large plum tomatoes
 - 4 garlic cloves, unpeeled
 - 350ml vegetable stock
 - 15ml tomato puree
 - Salt and pepper
1. Preheat the oven to 200°C/Gas mark 4.
 2. Place the peppers (cut side down), onion, tomatoes and garlic on a baking tray.
 3. Cook in the pre-heated oven for 30 minutes or until tender and well browned.
 4. Leave the vegetables to cool for 10 minutes then peel them. Place the vegetables and half the stock in the blender and blend on a low speed setting until smooth.
 5. Place in a pan and add the remaining stock and tomato puree.
 6. Bring to the boil.
 7. Season to taste and serve.

Hearty Hummus

- 410g can of chick peas in salted water
- 2 cloves garlic, peeled
- 2 teaspoons of light tahini
- 2 tablespoons of Greek yogurt
- Juice of ½ lemon
- 60ml extra virgin olive oil
- 2 teaspoons of cumin powder
- Salt and freshly ground black pepper

To garnish: Olive oil and cayenne pepper

1. Drain the chick peas, reserving the liquid.
2. Place 75ml (5tbsp) of the reserved liquid along with the rest of the ingredients into the blender jug and blend on a high speed setting.
3. The finished hummus should be smooth and creamy.
4. Transfer what you need to a serving dish, drizzle over a little more olive oil and sprinkle with cayenne pepper. Pour the rest into an airtight container and refrigerate.

Tomato and Avocado Salsa

- 4 large ripe tomatoes
 - 1 red chilli
 - ½ teaspoon ground cumin
 - ½ teaspoon ground coriander
 - Juice of 1 lime
 - 1 small red onion
 - 2 medium-ripe avocados (halved, stoned)
 - 2 tablespoons extra virgin olive oil
 - 8 tablespoons of roughly of coriander leaves
 - Salt and black pepper
1. Roughly chop the tomatoes, avocado and onion into big chunks and add to the blender jug along with the other ingredients.
 2. Chop with quick pulses until all the ingredients are combined but still chunky
 3. Serve with nachos and chopped carrot sticks

French Style Dressing

- 60ml white wine vinegar
 - 275ml sunflower oil
 - 2 cloves garlic, peeled
 - 1 tablespoon of Dijon mustard
 - 2 teaspoons dried mixed herbs
 - 1 tablespoon caster sugar
 - Salt and freshly ground black pepper
1. Place all of the ingredients in the blender jug and blend together on a high speed setting.
 2. Pour into a clean glass bottle or jam jar and store in the refrigerator until needed.
 3. Shake before using.

▲ Make sure the unit is switched off and unplugged from the mains supply socket before cleaning.

The blending blades are very sharp, take extreme caution when washing the jug.

Do not immerse the motor base, mains lead or plug in water or any other liquid.

Cleaning

- Wash the jug in warm, soapy water or in a dishwasher. Rinse and dry thoroughly. If necessary, use a washing up brush to get rid of any stubborn food deposits which have stuck around the blade.
- Wash jug lid and stopper in warm, soapy water or in a dishwasher. Rinse and dry thoroughly.
- Using a damp cloth or sponge, wipe down the motor base and dry thoroughly. Make sure you only use a mild detergent solution.

Quick cleaning method

1. Half fill the blender with warm water and a small amount of detergent.
2. Hold the speed control in the ICE CRUSH position for 10-20 seconds.
3. Remove the jug and rinse it under running water.

Storing

When storing the blender, assemble all parts and store in a safe, dry place, out of the reach of children.

connection to the mains supply

If the plug is not suitable for the socket outlets in your home, it can be removed and replaced by a plug of the correct type.

If the fuse in a moulded plug needs to be changed, the fuse cover must be refitted. The appliance must not be used without the fuse cover fitted.

If the plug is unsuitable, it should be dismantled and removed from the supply cord and an appropriate plug fitted as detailed. If you remove the plug it must not be connected to a 13 amp socket and the plug must be disposed of immediately.

If the terminals in the plug are not marked or if you are unsure about the installation of the plug please contact a qualified electrician.



This symbol indicates that this unit is a Class II appliance and therefore an earth connection is not required.

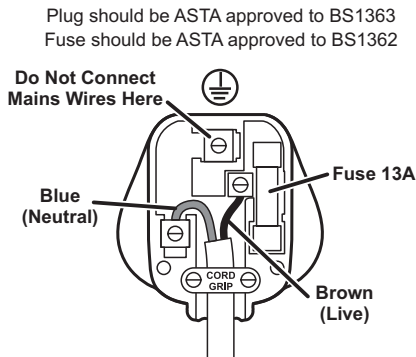

Ensure that the outer sheath of the cable is firmly held by the cord grip

These appliances are built to the very highest of standards. There are no user serviceable parts. Follow these steps if the unit fails to operate:

1. Check the instructions have been followed correctly.
2. Check that the fuse has not blown.
3. Check that the mains supply is functional.

If the appliance will still not operate, return the appliance to the place it was purchased for a replacement. To return the appliance to the Customer Service Department, follow the steps below:

1. Pack it carefully (preferably in the original carton). Ensure the unit is clean.
2. Enclose your name and address and quote the model number on all correspondence.
3. Give the reason why you are returning it.
4. If within the guarantee period, state when and where it was purchased and include proof of purchase (e.g. till receipt).
5. Send it to our Customer Service Department at the address below:

Customer Service Department
Jarden Consumer Solutions (Europe) Limited
Middleton Road, Royton, Oldham OL2 5LN, UK.
Telephone: 0161 621 6900 Fax: 0161 626 0391
e-mail: enquiriesEurope@jardencs.com

Replacement parts

For additional or replacement parts, please visit www.breville.co.uk or call us on **0161 621 6900**.

Troubleshooting

For troubleshooting and FAQs visit www.breville.co.uk/faqs

Turn on your Creativity™

Let the Breville® team help you turn on your creativity with a gateway to a world of food and drinks without limits. You don't have to travel far—just to your computer, tablet or mobile—where you will discover our FREE website with top tips and recipes to inspire your imagination. Join us now at www.turnonyourcreativity.com

Turn  your creativity™

guarantee

Please keep your receipt as this will be required for any claims under this guarantee.

This appliance is guaranteed for 1 year after your purchase as described in this document.

During this guaranteed period, if in the unlikely event the appliance no longer functions due to a design or manufacturing fault, please take it back to the place of purchase, with your till receipt and a copy of this guarantee.

The rights and benefits under this guarantee are additional to your statutory rights, which are not affected by this guarantee. Only Jarden Consumer Solutions (Europe) Limited (“JCS (Europe)”) has the right to change these terms.

JCS (Europe) undertakes within the guarantee period to repair or replace the appliance, or any part of appliance found to be not working properly free of charge provided that:

- you promptly notify the place of purchase or JCS (Europe) of the problem; and
- the appliance has not been altered in any way or subjected to damage, misuse, abuse, repair or alteration by a person other than a person authorised by JCS (Europe).

Faults that occur through, improper use, damage, abuse, use with incorrect voltage, acts of nature, events beyond the control of JCS (Europe), repair or alteration by a person other than a person authorised by JCS (Europe) or failure to follow instructions for use are not covered by this guarantee. Additionally, normal wear and tear, including, but not limited to, minor discoloration and scratches are not covered by this guarantee.

The rights under this guarantee shall only apply to the original purchaser and shall not extend to commercial or communal use.

If your appliance includes a country-specific guarantee or warranty insert please refer to the terms and conditions of such guarantee or warranty in place of this guarantee or contact your local authorized dealer for more information.

Waste electrical products should not be disposed of with household waste. Please recycle where facilities exist. E-mail us at enquiriesEurope@jardencs.com for further recycling and WEEE information.

Jarden Consumer Solutions (Europe) Limited
5400 Lakeside
Cheadle Royal Business Park
Cheadle
SK8 3GQ
UK

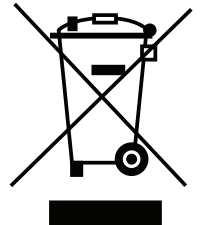

Breville®

Jarden Consumer Solutions (Europe) Limited
Cheadle Royal Business Park, Cheadle, SK8 3GQ, United Kingdom
e-mail: enquiriesEurope@jardencs.com
Telephone: 0161 621 6900

For Customer Service details, please see the website.

www.breville.co.uk

© 2014 Jarden Consumer Solutions (Europe) Limited

All rights reserved. Imported and distributed by Jarden Consumer Solutions (Europe) Limited,
Cheadle Royal Business Park, Cheadle, SK8 3GQ, United Kingdom.

The product supplied may differ slightly from the one illustrated due to continuing product development.

Printed in China