

# Breville®

Turn **on** your creativity®



**stainless steel**  
jug kettle

## product safety

---

**This appliance can be used by children aged from 8 years and above and persons with reduced physical, sensory or mental capabilities or lack of experience and knowledge if they have been given supervision or instruction concerning use of the appliance in a safe way and understand the hazards involved. Children shall not play with the appliance. Cleaning and user maintenance shall not be made by children unless they are older than 8 and supervised. Keep the appliance and its cord out of the reach of children aged less than 8 years.**

**Never use a power base other than the one supplied with the appliance.**

**Never fill the kettle above the MAX marking. If the kettle is overfilled, boiling water may be ejected.**

**If the supply cord is damaged, it must be replaced by the manufacturer, its service agent or similarly qualified persons in order to avoid a hazard.**

**Please read these instructions before operating the appliance and retain them for future use.**

- ⚠ This appliance generates heat during use. Adequate precaution must be taken to prevent the risk of burns, scalds, fires or other damage to persons or property caused by touching the exterior whilst in use or during cooling.
- ⚠ Never use this appliance for anything other than its intended use. This appliance is for household use only. Do not use this appliance outdoors.
- ⚠ Always ensure that hands are dry before handling the plug or switching on the appliance.
- ⚠ Always use the appliance on a stable, secure, dry and level surface.
- ⚠ This appliance must not be placed on or near any potentially hot surfaces (such as a gas or electric hob).
- ⚠ Do not use the appliance if it has been dropped, if there are any visible signs of damage or if it is leaking.
- ⚠ Ensure the appliance is switched off and unplugged from the supply socket after use and before cleaning.
- ⚠ Always allow the appliance to cool before cleaning or storing.
- ⚠ Never immerse any part of the appliance or power cord and plug in water or any other liquid.
- ⚠ Never let the power cord hang over the edge of a work top, touch hot surfaces or become knotted, trapped or pinched.
- ⚠ Never leave the appliance unattended when in use.
- ⚠ Beware of steam coming from the spout or lid especially during refilling. Never open the lid during the boiling cycle.
- ⚠ Never fill the appliance when it is positioned on the power base.
- ⚠ Never use the kettle without sufficient water in the kettle for it to operate correctly.
- ⚠ Never allow the appliance to boil dry.

# features

---



- 1 Spout**
- 2 Lid**
- 3 Handle**
- 4 Water level window**
- 5 Illuminated on/off switch**
- 6 360° rotational power base with cord storage**
- 7 Easy clean, fast boil concealed element**

Due to our policy of continuous improvement, the actual product may differ slightly from the one illustrated in these instructions.

Remove any packaging and promotional material from your kettle and position it on a stable, secure, dry and level work surface away from the edge.

Before connecting to a power source, make sure your mains supply voltage is the same as the one indicated on the appliance. Connect the plug to a suitable power outlet and make sure that the power cord does not overhang the work surface. Excess power cord can be stored in the power base.

Remove the kettle from the power base and open the lid. Fill your kettle to the maximum mark and close the lid.

Place the kettle back onto the power base. Switch the kettle on, allow it to boil then discard the water. Repeat twice. This will remove any residue left over from the manufacturing process.

# using your kettle

---

**▲ If this kettle is filled above the maximum level mark, hot water may be ejected from the spout during boiling. Beware of steam coming from the spout or lid especially during refilling. Never open the lid when the kettle is boiling.**

1. With the kettle switched off, plug the power base into a suitable power outlet.
2. Remove the kettle from the power base before filling it with water.
3. Fill the kettle with water. Don't overfill the kettle and always ensure that there is sufficient water in the kettle for it to operate correctly. This is approximately 250ml or 1 teacup full. Always check the water level when the kettle is positioned on its power base.
4. Close the lid and then switch the kettle on. Make sure that the lid is closed correctly to ensure safe operation.
5. When the kettle is switched on, the water level window and the on/off switch will illuminate.
6. When the water reaches boiling point, the kettle will switch off automatically.
7. You may also switch the kettle off manually at any time by moving the switch to the off position.

Always use caution when carrying your kettle when it is full of boiling water and when pouring it.

## Energy saving hints and tips

A Breville® kettle, if used correctly, is a very energy efficient device. Why not try some of these energy saving tips:

- Only boil the water you need. Overfilling your kettle by one cup is the equivalent to using an energy saving light bulb for one hour!
- It is not always necessary to re-boil your kettle. For example, one litre of water will still be at 90°C after five minutes - the perfect temperature for a cup of coffee.

## If the kettle boils dry

If the kettle is operated with insufficient water a built in fail-safe device will automatically switch off the kettle.

- Unplug the kettle and allow it to cool. When the kettle has cooled down sufficiently the device will reset itself.
- Once the device has reset, refill the kettle with cold water and use it as normal.

**▲ Always unplug the kettle from the mains supply socket and allow it to completely cool down before cleaning or descaling it. Do not immerse the kettle, power base or power cord and plug in water or any other liquid.**

1. Clean the exterior surface of the kettle with a damp cloth and then polish with a soft dry cloth. Do not use steel wool pads or harsh/abrasive cleaners.
2. Descale your kettle regularly to keep it working efficiently. Use a proprietary descaling product following the manufacturer's instructions carefully.

## Cleaning the filter

**▲ Before removing or refitting the filter, switch off the kettle and empty it. Allow it to cool completely, then unplug the power base from the mains supply socket. Never operate the kettle without the filter fitted.**

- Open the lid and remove the filter from behind the spout.
- Rinse the filter under a tap whilst brushing it with a soft brush.
- In hard water areas it may be necessary to descale the filter using a descaling agent. Use a proprietary descaling product following the manufacturer's instructions carefully.
- The filter may be washed safely in the cutlery rack of a dishwasher.
- Refit the filter back into the kettle.

## Turn on your Creativity®

Let the Breville® team help you turn on your creativity with a gateway to a world of food and drinks without limits. You don't have to travel far—just to your computer, tablet or mobile—where you will discover our FREE website with top tips and recipes to inspire your imagination. Join us now at:

[www.turnonyourcreativity.com](http://www.turnonyourcreativity.com)

Turn  your creativity®

# connection to the mains supply

---

**⚠ This appliance must be earthed.**

If the plug is not suitable for the socket outlets in your home, it can be removed and replaced by a plug of the correct type.

If the fuse in a moulded plug needs to be changed, the fuse cover must be refitted. The appliance must not be used without the fuse cover fitted.

If the plug is unsuitable, it should be dismantled and removed from the supply cord and an appropriate plug fitted as detailed. If you remove the plug it must not be connected to a 13 amp socket and the plug must be disposed of immediately.

If the terminals in the plug are not marked or if you are unsure about the installation of the plug please contact a qualified electrician.

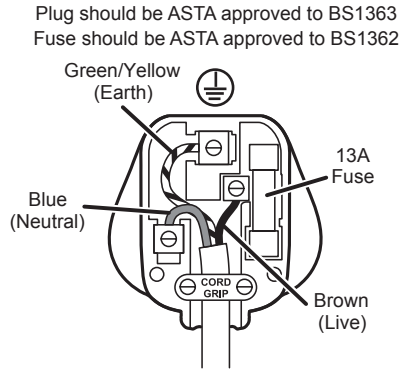

Ensure that the outer sheath of the cable is firmly held by the cord grip



These appliances are built to the very highest of standards. There are no user serviceable parts. Follow these steps if the unit fails to operate:

1. Check the instructions have been followed correctly.
2. Check that the fuse has not blown.
3. Check that the mains supply is functional.

If the appliance will still not operate, return the appliance to the place it was purchased for a replacement. To return the appliance to the Customer Service Department, follow the steps below:

1. Pack it carefully (preferably in the original carton). Ensure the unit is clean.
2. Enclose your name and address and quote the model number on all correspondence.
3. Give the reason why you are returning it.
4. If within the guarantee period, state when and where it was purchased and include proof of purchase (e.g. till receipt).
5. Send it to our Customer Service Department at the address below:

**Customer Service Department**  
**Jarden Consumer Solutions (Europe) Limited**  
**Middleton Road, Royton, Oldham**  
**OL2 5LN, UK**  
**Telephone: 0161 621 6900 Fax: 0161 626 0391**  
**e-mail: [enquiriesEurope@jardencs.com](mailto:enquiriesEurope@jardencs.com)**

# guarantee

---

Please keep your receipt as this will be required for any claims under this guarantee.

This appliance is guaranteed for 1 year after your purchase as described in this document.

During this guaranteed period, if in the unlikely event the appliance no longer functions due to a design or manufacturing fault, please take it back to the place of purchase, with your till receipt and a copy of this guarantee.

The rights and benefits under this guarantee are additional to your statutory rights, which are not affected by this guarantee. Only Jarden Consumer Solutions (Europe) Limited (“JCS (Europe)”) has the right to change these terms.

JCS (Europe) undertakes within the guarantee period to repair or replace the appliance, or any part of appliance found to be not working properly free of charge provided that:

- you promptly notify the place of purchase or JCS (Europe) of the problem; and
- the appliance has not been altered in any way or subjected to damage, misuse, abuse, repair or alteration by a person other than a person authorised by JCS (Europe).

Faults that occur through, improper use, damage, abuse, use with incorrect voltage, acts of nature, events beyond the control of JCS (Europe), repair or alteration by a person other than a person authorised by JCS (Europe) or failure to follow instructions for use are not covered by this guarantee. Additionally, normal wear and tear, including, but not limited to, minor discoloration and scratches are not covered by this guarantee.

The rights under this guarantee shall only apply to the original purchaser and shall not extend to commercial or communal use.

If your appliance includes a country-specific guarantee or warranty insert please refer to the terms and conditions of such guarantee or warranty in place of this guarantee or contact your local authorized dealer for more information.

Waste electrical products should not be disposed of with household waste. Please recycle where facilities exist. E-mail us at [enquiriesEurope@jardencs.com](mailto:enquiriesEurope@jardencs.com) for further recycling and WEEE information.

Jarden Consumer Solutions (Europe) Limited  
5400 Lakeside  
Cheadle Royal Business Park  
Cheadle  
SK8 3GQ  
UK

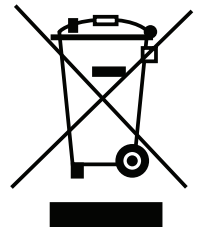

## replacement parts

---

For replacement parts, phone our Customer Service Department on 0161 621 6900. They will give you up to date prices, inclusive of VAT and postage and packaging.

# Breville®

Jarden Consumer Solutions (Europe) Limited  
Cheadle Royal Business Park, Cheadle, SK8 3GQ, United Kingdom  
e-mail: [enquiriesEurope@jardencs.com](mailto:enquiriesEurope@jardencs.com)  
Telephone: 0161 621 6900

For Customer Service details, please see the website.

[www.breville.co.uk](http://www.breville.co.uk)

**© 2015 Jarden Consumer Solutions (Europe) Limited**

All rights reserved. Imported and distributed by Jarden Consumer Solutions (Europe) Limited,  
Cheadle Royal Business Park, Cheadle, SK8 3GQ, United Kingdom.

The product supplied may differ slightly from the one illustrated due to continuing product development.

Printed in China