

Breville®

Turn **on** your creativity™



coffeeexpress™

READ CAREFULLY AND KEEP FOR FUTURE REFERENCE

This appliance can be used by children aged from 8 years and above if they have been given supervision or instruction concerning use of the appliance in a safe way and if they understand the hazards involved. Cleaning and user maintenance shall not be made by children unless they are older than 8 and supervised. Keep the appliance and its cord out of reach of children aged less than 8 years.

If the supply cord is damaged, it must be replaced by the manufacturer, its service agent or similarly qualified persons in order to avoid a hazard.

- △ This appliance generates heat during use. Adequate precaution must be taken to prevent the risk of burns, scalds, fires or other damage to persons or property caused by touching the exterior whilst in use or during cooling.
- △ Never use this appliance for anything other than its intended use. This appliance is for household use only. Do not use this appliance outdoors.
- △ Always ensure that hands are dry before handling the plug or switching on the appliance.
- △ Always use the appliance on a stable, secure, dry and level surface.
- △ This appliance must not be placed on or near any potentially hot surfaces (such as a gas or electric hob).
- △ Do not use the appliance if it has been dropped, if there are any visible signs of damage or if it is leaking.
- △ Ensure the appliance is switched off and unplugged from the supply socket after use and before cleaning.
- △ Always allow the appliance to cool before cleaning or storing.
- △ Never immerse any part of the appliance or power cord and plug in water or any other liquid.
- △ Never let the power cord hang over the edge of a worktop, touch hot surfaces or become knotted, trapped or pinched.
- △ Never leave the appliance unattended when in use.
- △ Never open the lid when the appliance is operating.

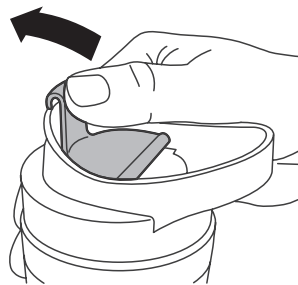
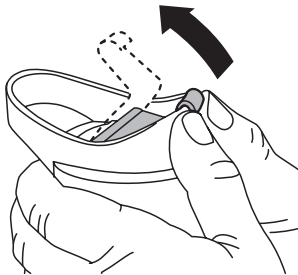
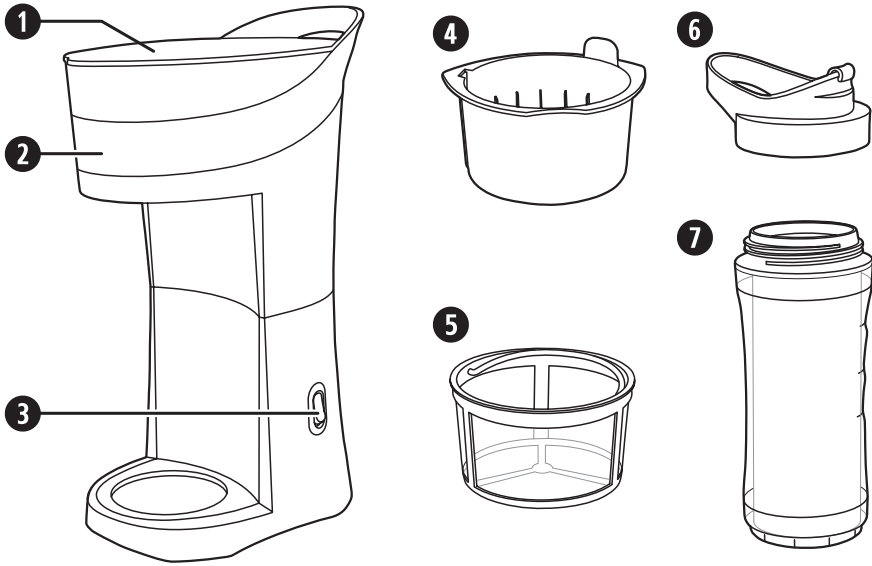

- 1 Lid
- 2 Filter/water chamber
- 3 On/off switch
- 4 Filter holder
- 5 Permanent gold tone filter
- 6 Lid with flip-cap
- 7 500ml sports-style bottle with stainless steel inner

The bottle is made from Eastman Tritan™ copolyester which is a durable BPA-free, odour, taste and stain resistant material used for manufacturing sports bottles and able to withstand extreme use and repeated dishwasher cleaning.

using your coffee maker

▲ Ensure that the appliance is switched off and unplugged from the supply socket if it is left unattended and before assembling, disassembling or cleaning.

Remove any packaging and promotional material from your coffee maker and position it on a stable, secure, dry and level work surface away from the edge. Wash all parts that will come into contact with food. Use warm soapy water then rinse and dry thoroughly.

Before making coffee for the first time, operate your coffee maker with plain water to flush the system through.

- Follow steps 1 to 5 below but without adding any coffee at step 4.
- Once the brewing cycle has completed, discard the contents of the bottle.

Making Coffee

1. Open the lid and fill with cold water to the 130, 300 or MAX marking (inside the water tank). The MAX marking is enough to completely fill the 500ml bottle. Make sure that you pour the water into the water tank and not the filter compartment. Don't exceed the MAX marking.
2. Fit the filter holder.
3. Fit the filter. Alternatively, you can use a paper filter shaped to fit the filter holder.
4. Add the filter coffee. For a 500mml bottle, add approximately 25g of coffee (or to taste). Close the lid.
5. Place the bottle onto the base. Plug your coffee maker in to the mains supply outlet. Press the on/off switch firmly until it lights up. Your coffee maker will start to brew the coffee.
6. When the brewing cycle has finished, the on/off switch light will go out. Remove the bottle, add milk and sugar as required then screw on the lid.

Notes

Freshly brewed coffee will be HOT! Take care when drinking.

Your coffee maker requires a rest period of three minutes between each brewing cycle. If you try to press the on/off switch during this time, nothing will happen. You can use this time to prepare your coffee maker by refilling the water tank and emptying and cleaning the used coffee grounds from the filter.

using your coffee maker

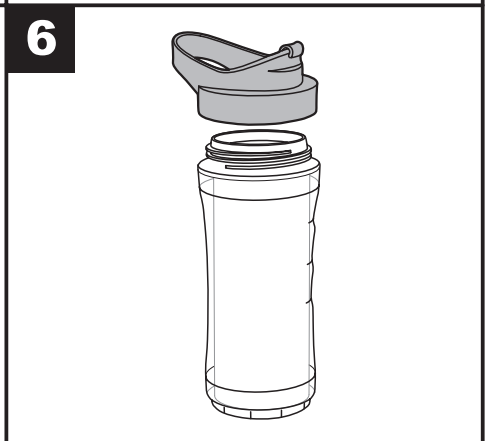
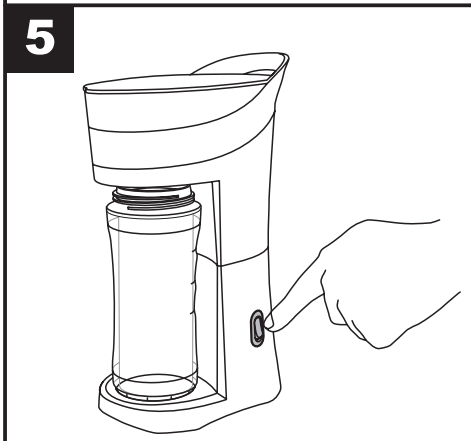
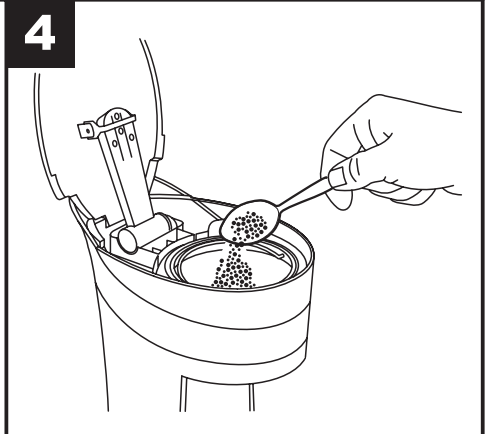
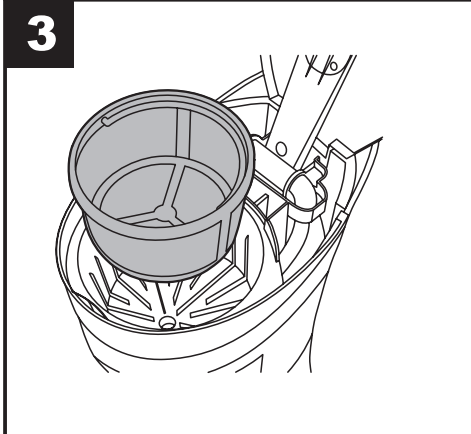
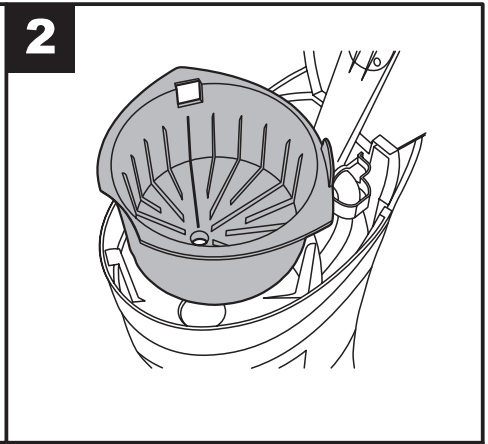
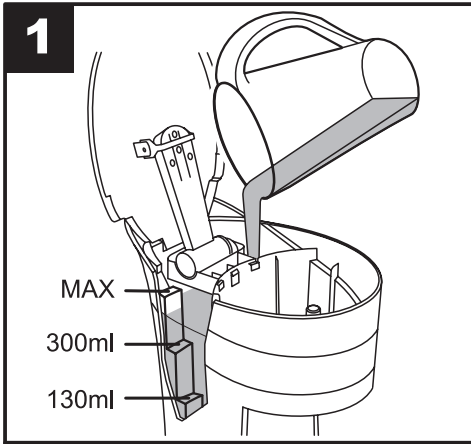

cleaning and storage

▲ Ensure that the appliance is switched off and unplugged from the supply socket if it is left unattended and before assembling, disassembling or cleaning.

Never immerse the main unit or power cord and plug in water or any other liquid.

Never use harsh, abrasive or caustic cleaners to clean this appliance.

Cleaning

- Remove the stainless steel inner from the bottle by unscrewing the base as shown. Don't wash the bottle without disassembling it otherwise water will be trapped inside.

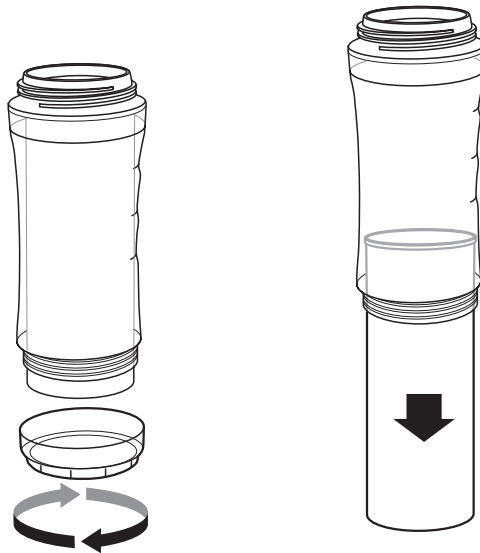

- Wash the bottle, stainless steel inner and lid in warm, soapy water. Rinse and dry thoroughly. Alternatively, these parts can be washed in a dishwasher.
- Wipe over the main unit with a damp cloth only.
- Wash the filter holder and filter in warm, soapy water. Rinse and dry thoroughly. Alternatively, the filter holder and filter can be washed in a dishwasher.

Storing

Store your coffee maker in its packing or in a clean, dry place. Ensure all parts are clean and dry before storing. Keep the appliance out of the reach of children.

These appliances are built to the very highest of standards. There are no user serviceable parts. Follow these steps if the unit fails to operate:

1. Check the instructions have been followed correctly.
2. Check that the fuse has not blown.
3. Check that the mains supply is functional.

If the appliance will still not operate, return the appliance to the place it was purchased for a replacement. To return the appliance to the Customer Service Department, follow the steps below:

1. Pack it carefully (preferably in the original carton). Ensure the unit is clean.
2. Enclose your name and address and quote the model number (located on the rating label) on all correspondence.
3. Give the reason why you are returning it.
4. If within the guarantee period, state when and where it was purchased and include proof of purchase (e.g. till receipt).
5. Send it to our Customer Service Department at the address below:

Customer Service Department

Jarden Consumer Solutions (Europe) Limited

Middleton Road, Royton, Oldham OL2 5LN, UK.

Telephone: 0800 525 089 Fax: 0161 626 0391

e-mail: enquiriesEurope@jardencs.com

Replacement parts

For additional or replacement bottles, please visit www.breville.co.uk or call us on **0161 621 6900**.

Troubleshooting

For troubleshooting and FAQs visit www.breville.co.uk/faqs

Turn on your Creativity™

Let the Breville® team help you turn on your creativity with a gateway to a world of food and drinks without limits. You don't have to travel far—just to your computer, tablet or mobile—where you will discover our FREE website with top tips and recipes to inspire your imagination. Join us now at www.turnonyourcreativity.com

Turn  your creativity™

connection to the mains supply

⚠ This appliance must be earthed.

If the plug is not suitable for the socket outlets in your home, it can be removed and replaced by a plug of the correct type.

If the fuse in a moulded plug needs to be changed, the fuse cover must be refitted. The appliance must not be used without the fuse cover fitted.

If the plug is unsuitable, it should be dismantled and removed from the supply cord and an appropriate plug fitted as detailed. If you remove the plug it must not be connected to a 13 amp socket and the plug must be disposed of immediately.

If the terminals in the plug are not marked or if you are unsure about the installation of the plug please contact a qualified electrician.

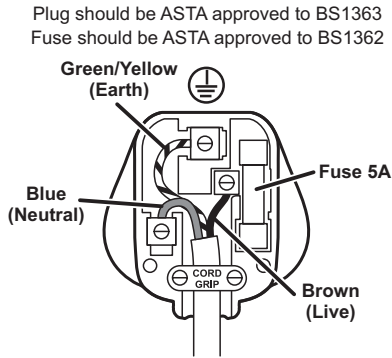

Ensure that the outer sheath of the cable is firmly held by the cord grip

Please keep your receipt as this will be required for any claims under this guarantee.

This appliance is guaranteed for 1 year after your purchase as described in this document.

During this guaranteed period, if in the unlikely event the appliance no longer functions due to a design or manufacturing fault, please take it back to the place of purchase, with your till receipt and a copy of this guarantee.

The rights and benefits under this guarantee are additional to your statutory rights, which are not affected by this guarantee. Only Jarden Consumer Solutions (Europe) Limited (“JCS (Europe)”) has the right to change these terms.

JCS (Europe) undertakes within the guarantee period to repair or replace the appliance, or any part of appliance found to be not working properly free of charge provided that:

- you promptly notify the place of purchase or JCS (Europe) of the problem; and
- the appliance has not been altered in any way or subjected to damage, misuse, abuse, repair or alteration by a person other than a person authorised by JCS (Europe).

Faults that occur through, improper use, damage, abuse, use with incorrect voltage, acts of nature, events beyond the control of JCS (Europe), repair or alteration by a person other than a person authorised by JCS (Europe) or failure to follow instructions for use are not covered by this guarantee. Additionally, normal wear and tear, including, but not limited to, minor discoloration and scratches are not covered by this guarantee.

The rights under this guarantee shall only apply to the original purchaser and shall not extend to commercial or communal use.

If your appliance includes a country-specific guarantee or warranty insert please refer to the terms and conditions of such guarantee or warranty in place of this guarantee or contact your local authorized dealer for more information.

Waste electrical products should not be disposed of with Household waste. Please recycle where facilities exist. E-mail us at enquiriesEurope@jardencs.com for further recycling and WEEE information.

Jarden Consumer Solutions (Europe) Limited
5400 Lakeside
Cheadle Royal Business Park
Cheadle
SK8 3GQ
UK

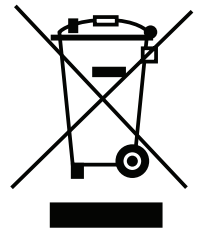

Breville®

Jarden Consumer Solutions (Europe) Limited
Cheadle Royal Business Park, Cheadle, SK8 3GQ, United Kingdom
e-mail: enquiriesEurope@jardencs.com
Telephone: 0161 621 6900

For Customer Service details, please see the website.

www.breville.co.uk

© 2014 Jarden Consumer Solutions (Europe) Limited

All rights reserved. Imported and distributed by Jarden Consumer Solutions (Europe) Limited,
Cheadle Royal Business Park, Cheadle, SK8 3GQ, United Kingdom.

The product supplied may differ slightly from the one illustrated due to continuing product development.

Printed in China